

ALUMINIUM REAR TIPPER

DMPT0

SC - L3

BODYWORK

- Tipper platform in high quality aluminium sheet: 5083 H16 thickness 3.5 mm
- Side members in extruded box-sections, thickness 3 mm, height 120 mm and outer frames in box-sections, thickness 3.5 mm, under the load surface
- Sideboards in extruded aluminium profile, height 400 mm (385 mm interior), double wall top and bottom, thickness 2.8 mm, single wall, thickness 3.5 mm in the centre, fold-down, removable, interchangeable (right/left)
- Locking handle incorporated into the thickness of the sideboards
- Front face, interior usable height 450 mm, double wall top and bottom, thickness 2.6 mm, single wall, thickness 3.5 mm in the centre
- Cab Protect with aluminium grille diameter 5 mm with frame in extruded profiles, removable and without top cap
- Aluminium rear door, height 450 mm, double wall top and bottom, thickness 2.8 mm, single wall, thickness 3.5 mm in the centre, automatic opening by cam of 15° (doorway 520 mm)
- Rubber opening stops on sideboards and rear door
- Rear pillars in galvanised steel, thickness 3 mm, removable, with 12 mm tightening fixing bolt and conical fitting
- Polypropylene fender flares with supports in unwrought aluminium
- Nickel Zinc treated bolts (5 times more resistant than standard galvanising)
- Tipping shaft without lubrication
- Outer frame adapted to lashing
- Lashing rings integrated into outer frame, TÜV-certified to DIN EN 12640, 800 daN
- Short dumping overhang: 250 mm
- Light grilles
- Aluminium back box 600x1300x2000 mm semi-painted (painted doors) 95 kg - supplied without shelf - **RRBX2**

SUBFRAME

- Aluminium profile tipper, thickness 4.5 to 12 mm
- Tipping by 3 or 4 expansion CYLINDER depending on length (no overhang under the subframe)
- 46° rear tipping angle
- Electrically driven pump unit, 12 volts
- 7-litre tank
- Hydraulic pressure 180 bars
- Wired remote control in cab

SAFETY

- Safety solenoid valve on cylinder
- Circuit breaker
- Safety stand
- Double safety device on the side-board handles
- Double safety device on the upper door hinges

OPTIONS

- Approved aluminium side protection, black powder paint (standard on N2 and EV, optional on N1) - **SMOLO**
- Side lights as standard on vehicles >6m
- Underride guard (Triva) with mixed hook (35 kg) – **RPB00**

SEMI-PAINTED FINISH

- Shot-blasted + 60 µm powder primer + 60 µm powder paint in JPM grey / RAL 7004 for the side panels, rear door, ladder rack and rear posts.
- Other elements in raw finish



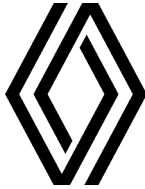

PROFILES / VARIANTS

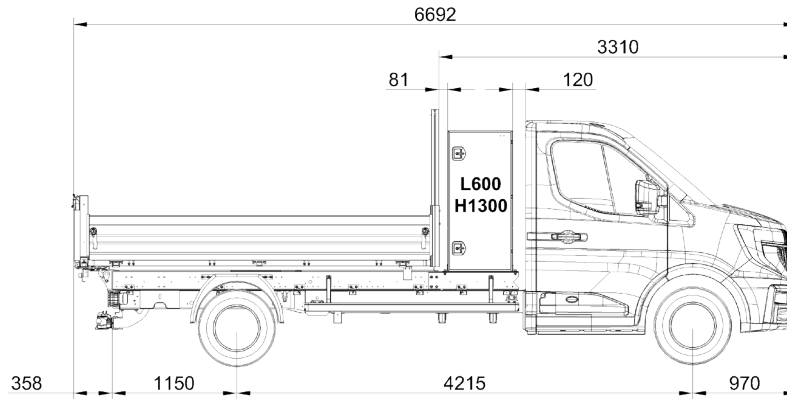

SC L3 FWD SRW - SC L3 e-Tech SRW - SC L3 RWD DRW

NET TIPPING CAPACITY & WEIGHT

Load uniformly distributed.

Weights are for information. Supplier thickness tolerances for steel or aluminium do not enable us to guarantee a weight within a tolerance of +/- 10%.

Tipper length (in mm)	Useful length (in mm)	Net tipping capacity (in metrics tons)	Bodywork weight (in kg)
3300	3260	4,42	473

AND GUARANTEE OF UP TO 5 YEARS FOR YOUR BODYWORK

2-YEAR GUARANTEE

On purchasing
your bodywork

3-YEAR GUARANTEE

3rd year free
after registering
your bodywork

5-YEAR GUARANTEE

JPM offers
a 2-year guarantee
extension