

# ENTERPRISE ALUMINIUM THREE-WAY TIPPER

DMPT3  
SC - L3

## BODYWORK

- Tipper platform in high quality aluminium sheet: 5083 H16 thickness 3.5 mm
- Side members in extruded box-sections, thickness 3 mm, height 120 mm and outer frames in box-sections, thickness 3.5 mm, under the load surface
- Sideboards in extruded aluminium profile, height 400 mm (385 mm interior), usable interior height 388.5 mm, double wall top and bottom, thickness 2.8 mm, single wall, thickness 3.5 mm in the centre, fold-down, removable, interchangeable (right/left)
- Locking handle incorporated into the thickness of the sideboards
- Front face, usable interior height 450 mm, double wall top and bottom, thickness 2.6 mm, single wall, thickness 3.5 mm in the centre
- Cab Protect with aluminium grille diameter 5 mm with frame in extruded profiles, removable and without top cap
- Aluminium Easydoor rear door, height 450 mm, double wall top and bottom, thickness 2.8 mm, single wall, thickness 3.5 mm in the centre, automatic opening by cam of 15° (doorway 520 mm) and manual downward opening
- Rubber opening stops on sideboards and rear door
- Rear pillars in galvanised steel, thickness 3 mm, removable, with 12 mm tightening fixing bolt and conical fitting
- Polypropylene fender flares with supports in unwrought aluminium
- Nickel Zinc treated bolts (5 times more resistant than standard galvanising)
- Tipping on aluminium spherical bearings and forks, contact on elastomer
- Locking pins in Nickel Zinc treated steel with code (preventing any false manoeuvre)
- Outer frame adapted to lashing
- Lashing rings integrated into outer frame, TÜV-certified to DIN EN 12640, 800 daN
- Short dumping overhang: 340 mm
- Aluminium back box 600x1300x2000 mm semi-painted (painted doors) 95 kg - supplied without shelf - **RRBX2**

## SUBFRAME

- Aluminium profile tipper, thickness 4.5 to 12 mm
- Tipping by COMPASS CYLINDER (no overhang under the subframe)
- Rear tipping angle of 48° and laterally 45°
- Electrically driven pump unit, 12 volts
- 3-litre tank
- Hydraulic pressure 320 bars
- Wired remote control in cab

## SAFETY

- Safety solenoid valve on cylinder
- Circuit breaker
- Safety stand
- Buzzer
- Double safety device on the sideboard handles
- Double safety device on the upper door hinges

## OPTIONS

- Approved aluminium side protection, black powder paint (standard on N2 and EV, optional on N1) - **SMOLO**
- Side lights as standard on vehicles >6m
- Underride guard (Triva) with mixed hook (35 kg) - **RPB00**

## SEMI-PAINTED FINISH

- Shot-blasted + 60 µm powder primer + 60 µm powder paint in JPM grey / RAL 7004 for the side panels, rear door, ladder rack and rear posts.
- Other elements in raw finish



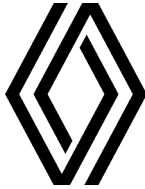

# ENTERPRISE ALUMINIUM THREE-WAY TIPPER

DMPT3  
SC - L3

## PROFILES / VARIANTS

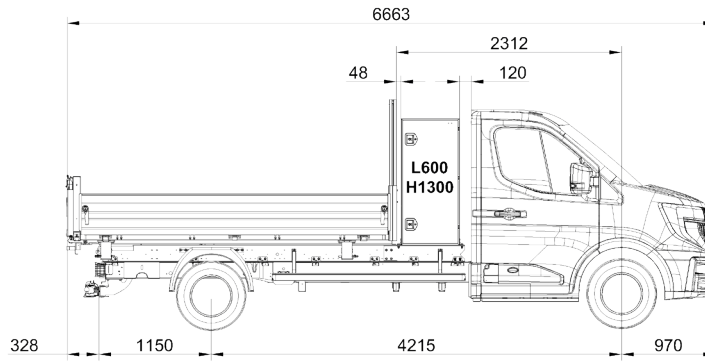

SC L3 FWD SRW - SC L3 e-Tech SRW - SC L3 RWD DRW

## NET TIPPING CAPACITY & WEIGHT

Load uniformly distributed.

Weights are for information. Supplier thickness tolerances for steel or aluminium do not enable us to guarantee a weight within a tolerance of +/- 10%.

Tipper length (in mm)	Useful length (in mm)	Net tipping capacity (in metric tons)	Bodywork weight (in kg)
3300	3260	4,69	541

## AND GUARANTEE OF UP TO 5 YEARS FOR YOUR BODYWORK

### 2-YEAR GUARANTEE

On purchasing  
your bodywork

### 3-YEAR GUARANTEE

3<sup>rd</sup> year free  
after registering  
your bodywork

### 5-YEAR GUARANTEE

JPM offers  
a 2-year guarantee  
extension



[www.jpm-group.com](http://www.jpm-group.com)